



**SUITABLE FOR FIXED-HEAD CNC LATHES
WITH SPINDLE CAPACITY
FROM 8 mm (0.31") TO 100 mm (3.93")**

**BAR STOCK HANDLING
VIA HMI PANEL**

ATTENTION:

The maximum workable length of the bar is equal to the lathe spindle length



BAR FEEDER LAYOUT

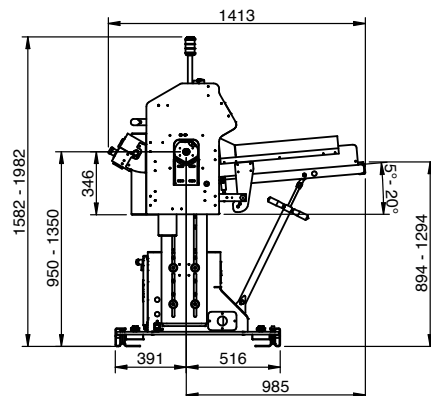
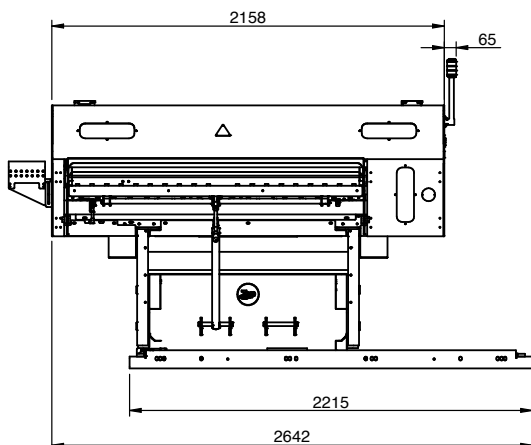



← Scan the QR CODE to watch the video



TECHNICAL DATA

∅ ROUND BARS
8 mm - 100 mm
0.31" - 3.93"

⬡ HEXAGONAL BARS
8 mm - 87 mm
0.31" - 3.42"

⊠ SQUARE BARS
8 mm - 71 mm
0.31" - 2.79"

↔ BAR LENGTH

200 mm - 1600 mm / 7.87" - 62.99"

⌚ MAX FEED SPEED
80 m/min - 262.46'/min

⏏ MAX REMNANT LENGTH
↔ not available

⚙️ AIR PRESSURE REQUIRED
not available



SELF ADJUSTING GUIDE CHANNEL

The bar feeder channel is mobile, allowing to process bar diameters ranging from 8 mm (0.31") up to 100 mm (3.93"); the system is managed by the PLC. The channel is entirely made in special plastic material, in order to grant a smooth and silent bar scrolling.



REPOSITIONING SYSTEM

In order to ease the spindle liners insertion, the bar feeder is equipped with a rail system that enables at 800 mm (31.49") radial or axial displacement (alternative option), helping also the lathe servicing. The bar feeder fastening, on its rails, is provided by fast block hooks.

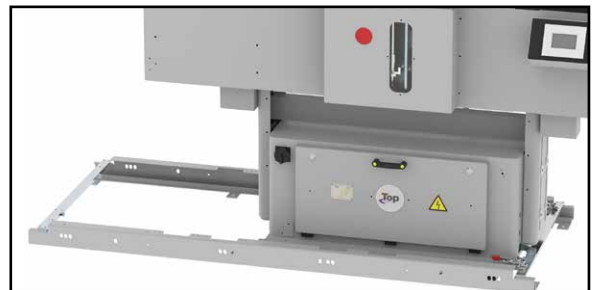

MAGIC BUSHING SYSTEM

The MAGIC BUSHING SYSTEM (sold apart) increase the lathe spindle length of 500mm (19.68"), allowing to process in complete safety, bars that normally would protrude from the back of the spindle.



SPINDLE LINERS

To achieve the full capability of the MAGIC bar feeder, the internal diameter of the spindle liners should not be larger than 5mm (0.19") more than the bar to process. The spindle liner can be fixed by means of a flange, bolted to the rear side of the lathe.



AUTOMATIC MANAGEMENT

The MAGIC bar feeder is completely managed by the PLC interacting with a Brushless motor and a pneumatic valves system which controls speed, thrust and all the automations. From the PLC the operator can shift from one diameter to another one in 60 seconds, simply entering the intended diameter on the keyboard.



BAR STORAGE

On demand, MAGIC can offer a multiple adjustable bar storage where the bars are stored side by side depending on the length worked, up to a maximum of 3 rows. This system, patented by Top Automazioni, makes the most of the bar storage capacity (for the reuse of remnants as well) and leads to a longer working cycle, avoiding the need to recharge frequently.

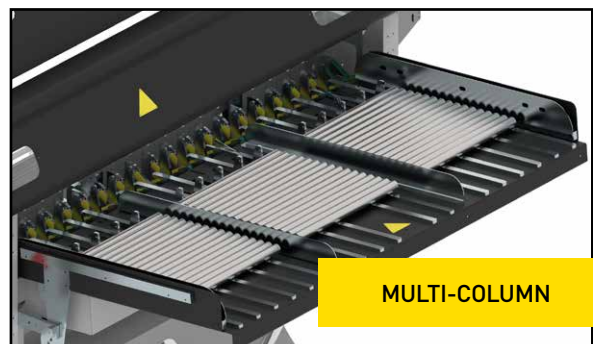



HOW TO FIND US ►
scan QR code



TOP AUTOMAZIONI S.R.L.

Via Torrianese, 62
47824 Poggio Torriana (RN)

Tel. +39 0541 688248
Fax +39 0541 688168

topautomazioni@topautomazioni.com
www.topautomazioni.com

